

REVISION RECORD				
REV	ECO	DESCRIPTION	DRFT	CHKD
△		DRAWING MODIFY	Among 11/25/04	
△		DRAWING MODIFY	Sammy 1/07/05	

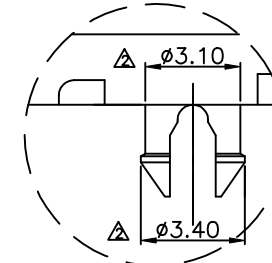

SECTION A-A

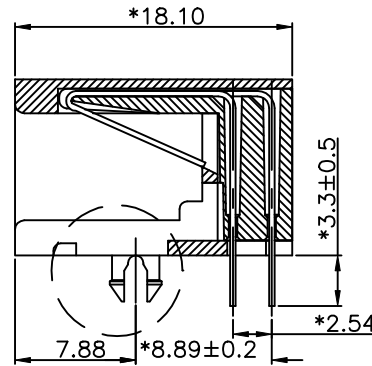
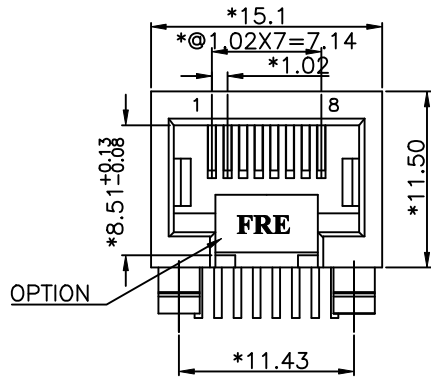
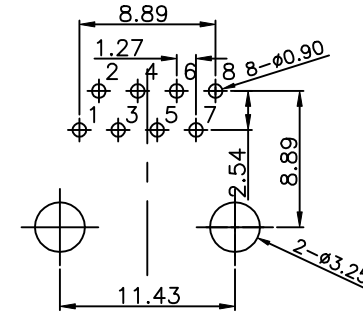
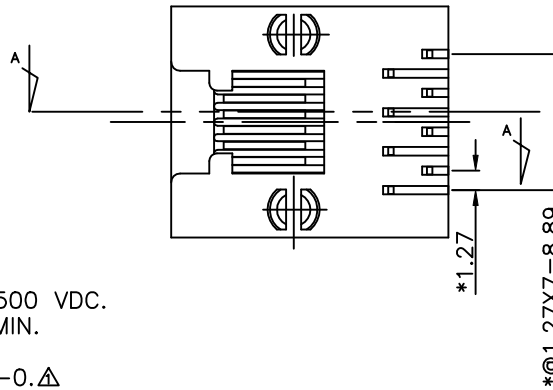

PCB T=1.60mm
PC BOARD LAYOUT COMPONENT SIDE SHOWN

NOTES:

ELECTRICAL:

1. VOLTAGE RATING : 125 VAC RMS.
2. CURRENT RATING : 1.5 AMP.
3. CONTACT RESISTANCE : 35 MILLIOHMS MAX.
4. INSULATION RESISTANCE: 1000 MEGOHMS MIN @ 500 VDC.
5. DIELECTRIC STRENGTH : 1000 VAC RMS 60Hz, 1MIN.

MECHANICAL:

1. HOUSING MATERIAL : HIGH TEM. UL94V-0.△
2. CONTACT MATERIAL : PHOSPHOR BRONZE t=0.35mm.
3. PLATING : GOLD PLATING OVER NICKEL.
4. OPERATING LIFE : 750 CYCLES MIN.
5. PCB RETENTION PRE-SOLDER : 1 LB MIN.
6. PCB RETENTION POST-SOLDER: 10 LBS MIN.

ENVIRONMENTAL:

1. STORAGE : -40°C TO +85°C.
2. OPERATION: -40°C TO +85°C.

MATES WITH MODULAR PLUG CONFORMING TO
FCC PART 68, SUBPART F.

CUL FILE NO. E163191

△△ PART NUMBER: E5388-E00XXX-L

- 1- 3u" 2- 6u"
- 3-15u" 4-30u"
- 5-50u" 6-Pd 20u"
- 50- W/FRE LOGO
- 5R- W/O FRE LOGO

← MM (INCH) →		DFTO KAN	DATE 1/28/99
TOLERANCES EXCEPT AS NOTED		CHKD QIANPU	DATE2005/1/19
		MFO	DATE
		APPVLLUSHENG	DATE2005/1/19
MM		MATERIAL :	
.0 ±0.20	±	QT'Y :	
.00 ±0.15	±	FINISH :	
.000 ±0.075	±	SCALE : 3:1	
ANGLES ±		THIRD ANGLE PROJECTION	

FULL RISE ELECTRONIC CO., LTD			
TITLE 11.5 SIDE ENTRY 8P FCC DEEP TYPE			
DRAWING NO. GE533098		SIZE	REV
/PART NO. SEE NOTE		A3	2
DO NOT SCALE DRAWING		SHEET X	OF Y